



MICRO SWITCH: MS-1281 **RoHS Compliant** Rev.03 09/03/2016

Part code: MS-1281-PL Description: Straight PCB terminal

Part code: MS-1281-DL Description: Right angle D terminal

Part code: MS-1281-P-XL Description: Straight PCB terminal long lever

MS-1281-P-XL: LONG LEVER

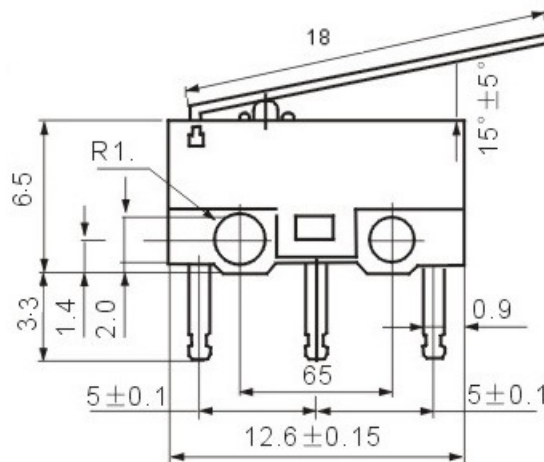

Electrical specifications:

Contact Rating	125V AC x 1A, 5V DC x 30mA
Contact Arrangement	SPDT
Operating Life Electrical	10,000 cycles
Dielectric Strength	500V AC for 1 min.
Insulation Resistance	100 M Ohms min.
Contact Resistance	100 milli Ohms max.
Max. Operating frequency	200 operations/min.
Ambient Temperature	-40 Deg. C to 85 Deg. C
Ambient Humidity	Less than 85% RH

Operating characteristics:

Operating Force O.F (max)	40gf ± 20gf
Return Force R.F (min)	5gf
Pre Travel P.T (max)	1.8mm ± 0.3mm
Over Travel O.T (min)	0.6mm
Operating position O.P	8.80 ± 0.8mm
Free position F.P	10.40 ± 0.8mm

Material Specifications:

Case	PBT G30
Plunger	POM
Cover	PC
Terminals	Brass Silver Plated
Contacts plate	Phosphor Bronze